

# ES 6000

Fully automatic  
labelling



ES 6001

ES 1000  
ES 2000  
ES 3000  
ES 4000  
ES 5000  
**ES 6000**  
ES 7000  
ES 8000  
ES 9000



# ES 6000

**Weigh-labelling for products up to 30 kg or 80 kg**

- Fully automatic machine with a wide range of labelling possibilities
- Labelling performance up to 40 packs per minute
- Interactive weigh-labelling by using the management system ESMS



**ES 6002 / 30 kg**  
Labelling from all sides

High-performance motor



Height adjustment by use of the gas-filled spring supported printer bridge

The free movable printer module and the turntable print system allow many different label positions.

The ES 6000 is available in many different variants.

With the ES 6001 the following labelling options are possible: labelling from the top, the back, the front and also the side.

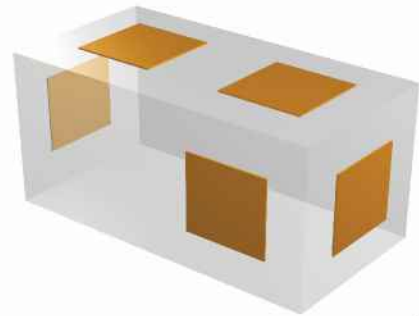

This machine can be integrated into the existing production line, whether in right or left running direction.

The compact ES 6100 with one conveyor only can label packages of up to 30 kg on the side, on the top or on the backside.



ES 6100

Safety device for 80 kg version

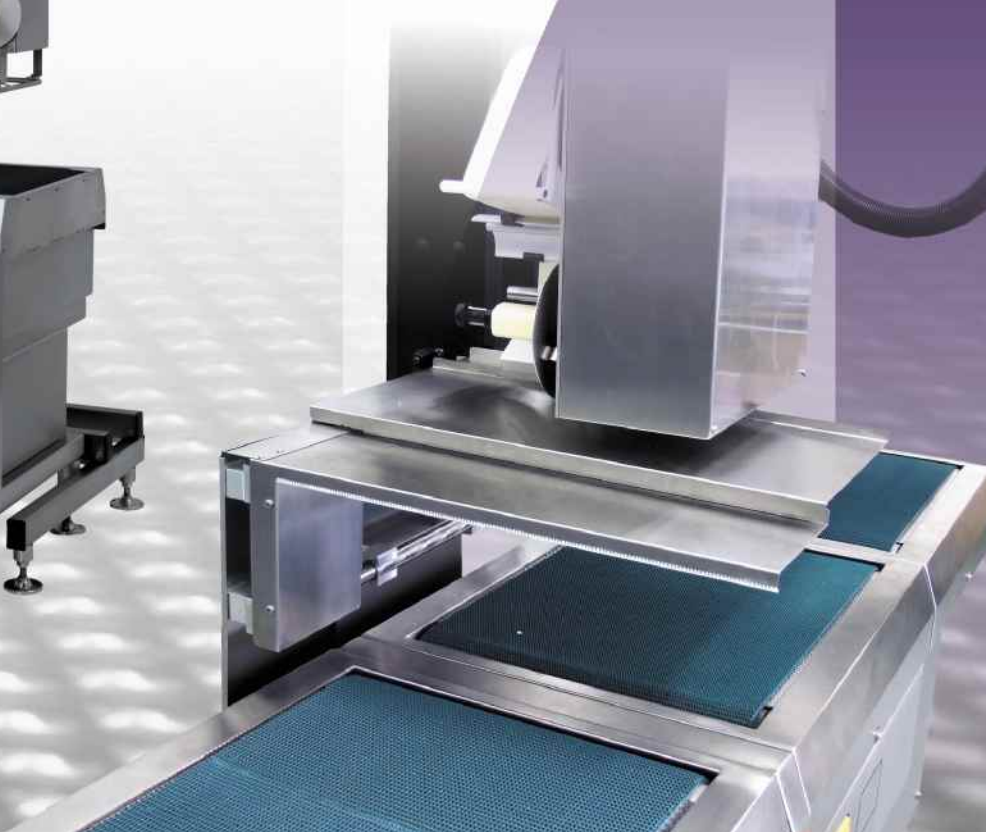

Model	ES 6000	ES 6100		
Terminal	ESC with touch screen			
User interface	ESMS			
Weighing range	30 / 80 kg*			
30 kg max. Last accuracy/calibration value	15 g	30 g		
80 kg max. load accuracy/calibration value	15 g	30 g	60 g	80 g
Package size in mm	L x W x H			
Maximum	550 x 500 x 480	500 x 500 x 480		
with add. conveyor	550 x 400 x 480	500 x 400 x 480		
with option for long packages	L 750 mm	L 600 mm		
Conveyor speed	variable			
Product detection	light barrier			
12 Dot/mm/300 dpi	yes			
Label passage	110 mm			
Maximum printing speed	250 mm/s			
Print width	104 mm			
Label minimum W x L	37 x 37 mm			
Label maximum W x L	106 x 170 mm**			
Label reel core / outside diameter	76 mm / 210 mm			
RS 232	yes			
USB	yes			
Memory	SSD			
Ethernet	yes			
Mains voltage	190 V to 260 V / 50 – 60 Hz			
Protection class	IP44***	IPX4***		
Operating temperature	-10 °C to +40 °C			

\* with safety device

\*\* depending on pack and label size

\*\*\* except printer, for mains voltage applying parts



IP terminal in a stainless steel housing

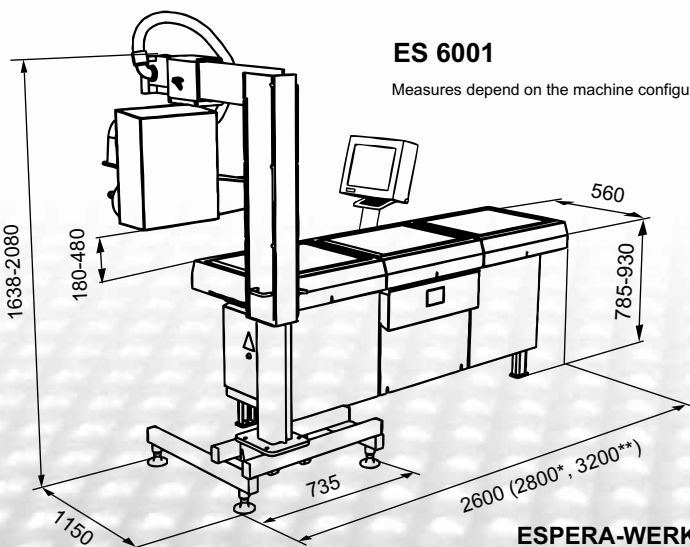

## ES 6001

Measures depend on the machine configuration

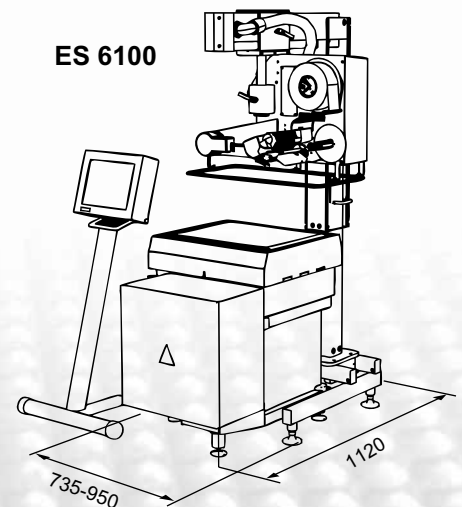

## ES 6100

\* with scale conveyor extension  
\*\* with optional infeed conveyor

## ESPERA-WERKE GMBH

Postfach 10 04 55 • 47004 Duisburg

Tel. +49(0)203/30 54 - 0 • Fax +49(0)203/30 54 - 275

info@espera.com • www.espera.com